

Dimensions of JIS 5K flanges

JIS 5K

JIS B 2220

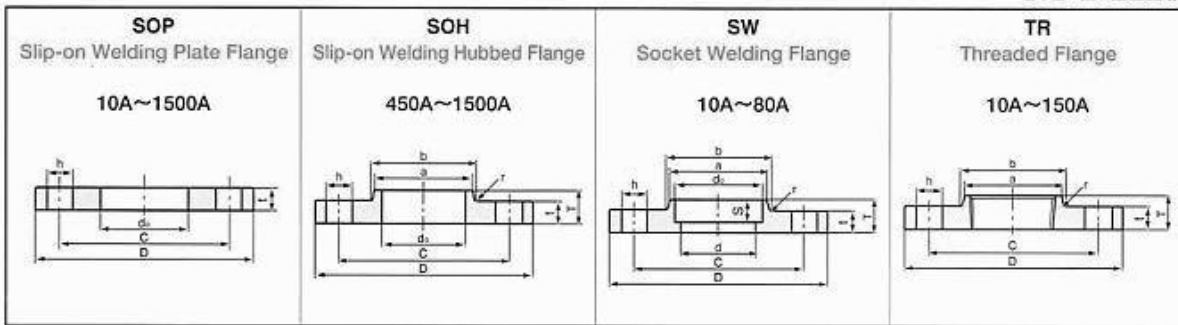

Unit : mm

Nominal Size	Outside Diameter	Bolt Circle Diameter	Diam. of Bolt Holes	Number of Bolt Holes	Bore			Depth of Socket	Designation of Thread	Raised Face	
					SOP SOH SW	LJ	SW WN (1)			Diameter	Height
					d ₀	d ₀	d	SW S	TR		
10	75	55	12	4	17.8	—	12.7	10	Rc 3/8	39	1
15	80	60	12	4	22.2	23.4	16.1	10	Rc 1/2	44	1
20	85	65	12	4	27.7	28.9	21.6	13	Rc 3/4	49	1
25	95	75	12	4	34.5	35.6	27.6	13	Rc 1	59	1
32	115	90	15	4	43.2	44.3	35.7	13	Rc 1 1/4	70	2
40	120	95	15	4	49.1	50.4	41.6	13	Rc 1 1/2	75	2
50	130	105	15	4	61.1	62.7	52.9	16	Rc 2	85	2
65	155	130	15	4	77.1	78.7	67.9	16	Rc 2 1/2	110	2
80	180	145	19	4	90.0	91.6	80.7	16	Rc 3	121	2
90	190	155	19	4	102.6	104.1	93.2	—	—	131	2
100	200	165	19	8	115.4	116.9	105.3	—	Rc 4	141	2
125	235	200	19	8	141.2	143.0	130.8	—	Rc 5	176	2
150	265	230	19	8	166.6	168.4	155.2	—	Rc 6	206	2
175	300	260	23	8	192.1	—	180.1	—	—	232	2
200	320	280	23	8	218.0	219.5	204.7	—	—	252	2
225	345	305	23	12	243.7	—	229.4	—	—	277	2
250	385	345	23	12	269.5	271.7	254.2	—	—	317	2
300	430	390	23	12	321.0	322.8	304.7	—	—	360	3
350	480	435	25	12	358.1	360.2	339.8	—	—	403	3
400	540	495	25	16	409	411.2	390.6	—	—	463	3
450	605	555	25	16	460	462.3	441.4	—	—	523	3
500	655	605	25	20	511	514.4	492.2	—	—	573	3
550	720	665	27	20	562	565.2	543.0	—	—	630	3
600	770	715	27	20	613	616.0	593.8	—	—	680	3
650	825	770	27	24	664	—	644.6	—	—	735	3
700	875	820	27	24	715	—	695.4	—	—	785	3
750	945	880	33	24	766	—	746.2	—	—	840	3
800	995	930	33	24	817	—	797.0	—	—	890	3
850	1045	980	33	24	868	—	847.8	—	—	940	3
900	1095	1030	33	24	919	—	898.6	—	—	990	3
1000	1195	1130	33	28	1021	—	1000.2	—	—	1090	3
1100	1305	1240	33	28	1122	—	1098.6	—	—	1200	3
1200	1420	1350	33	32	1224	—	1200.2	—	—	1305	3
1350	1575	1505	33	32	1376	—	1346.2	—	—	1460	3
1500	1730	1660	33	36	1529	—	1498.6	—	—	1615	3

Note: (1) The Bore d shall be adjusted by the inside diameter of the steel pipe to be joined.